

DM74ALS520/521 8-Bit Comparator

General Description

These comparators perform an "equal to" comparison of two 8-bit words with provision for expansion or external enabling. The matching of the two 8-bit input plus a logic LOW on the \overline{EN} input produces the output $\overline{A = B}$ on the ALS520 and 521. The ALS520 and 521 have totem pole outputs for wire AND cascading. Additionally, the ALS520 is provided with B input pull up termination resistors for analog or switch data.

Features

- Switching specifications at 50 pF
- Switching specifications guaranteed over full temperature and V_{CC} range
- Advanced oxide-isolated, ion-implanted Schottky TTL process
- Functionally and pin for pin compatible with LS family counterpart
- Improved output transient handling capability

Connection Diagram

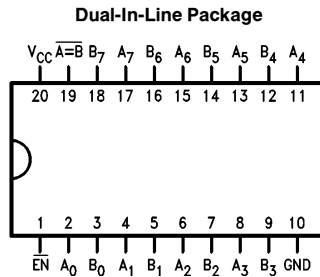

TL/F/6114-2

Order Number **DM74ALS520WM, DM74ALS521WM,**
DM74ALS520N or DM74ALS521N
 See NS Package Number **M20B or N20A**

Function Table

ALS520, 521

Inputs		Output
\overline{EN}	Data	$\overline{A = B}$
L	A = B	L
L	A \neq B	H
H	X	H

H = High Logic Level; L = Low Logic Level; X = Don't Care

Absolute Maximum Ratings

Supply Voltage	7V
Input Voltage	7V
Operating Free Air Temperature Range	
DM74ALS	0°C to +70°C
Storage Temperature Range	-65°C to +150°C
Typical θ_{JA}	
N Package	62.0°C/W
M Package	82.0°C/W

Note: The "Absolute Maximum Ratings" are those values beyond which the safety of the device cannot be guaranteed. The device should not be operated at these limits. The parametric values defined in the "Electrical Characteristics" table are not guaranteed at the absolute maximum ratings. The "Recommended Operating Conditions" table will define the conditions for actual device operation.

Recommended Operating Conditions

Symbol	Parameter	DM74ALS520, 521			Units
		Min	Nom	Max	
V_{CC}	Supply Voltage	4.5	5	5.5	V
V_{IH}	High Level Input Voltage	2			V
V_{IL}	Low Level Input Voltage			0.8	V
I_{OH}	High Level Output Current (ALS520, 521)			-2.6	mA
I_{OL}	Low Level Output Current			24	mA
T_A	Free Air Operating Temperature	0		70	°C

Electrical Characteristics

over recommended operating free air temperature range. All typical values are measured at $V_{CC} = 5V$, $T_A = 25^\circ C$.

Symbol	Parameter	Conditions	Min	Typ	Max	Units	
V_{IK}	Input Clamp Voltage	$V_{CC} = 4.5V$, $I_I = -18\text{ mA}$			-1.5	V	
V_{OH}	High Level Output Voltage	$V_{CC} = 4.5V$ to $5.5V$ $I_{OH} = -400\ \mu A$	ALS520, 521	$V_{CC} - 2$		V	
		$V_{CC} = 4.5V$ $I_{OH} = \text{Max}$			2.4	3.2	V
V_{OL}	Low Level Output Voltage	$V_{CC} = 4.5V$	74ALS $I_{OL} = 24\text{ mA}$	0.35	0.5	V	
I_I	Max High Input Current	$V_{CC} = 5.5V$	$V_{IH} = 5.5V$ B Input ALS520		0.1	mA	
			$V_{IH} = 7V$, All Others				
I_{IH}	High Level Input Current	$V_{CC} = 5.5V$, $V_{IH} = 2.7V$	All Others		20	μA	
			B Input ALS520		-200		
I_{IL}	Low Level Input Current	$V_{CC} = 5.5V$, $V_{IL} = 0.4V$	B Input ALS520		-0.6	mA	
			All Others		-0.1	mA	
I_O	Output Drive Current	$V_{CC} = 5.5V$	$V_O = 2.25V$ ALS520, 521	-30	-112	mA	
I_{CC}	Supply Current	$V_{CC} = 5.5V$ (Note 1)	ALS520, 521		12	19	mA

Note 1: I_{CC} is measured with \overline{EN} grounded, A and B inputs at 4.5V and outputs open.

Switching Characteristics over recommended operating free air temperature range (Note 1)

Symbol	Parameter	Conditions	From Input	To Output	DM74ALS 520, 521		Units
					Min	Max	
t _{PLH}	Propagation Delay Time Low to High Level Output	V _{CC} = 4.5V to 5.5V C _L = 50 pF R _L = 500Ω	A or B Data	$\overline{A = B}$	3	12	ns
t _{PHL}	Propagation Delay Time High to Low Level Output		A or B Data	$\overline{A = B}$	5	20	ns
t _{PLH}	Propagation Delay Time Low to High Level Output		\overline{EN}	$\overline{A = B}$	2	12	ns
t _{PHL}	Propagation Delay Time High to Low Level Output		\overline{EN}	$\overline{A = B}$	5	22	ns

Note 1: See Section 5 for test waveforms and output load.

Logic Diagrams

ALS520/521

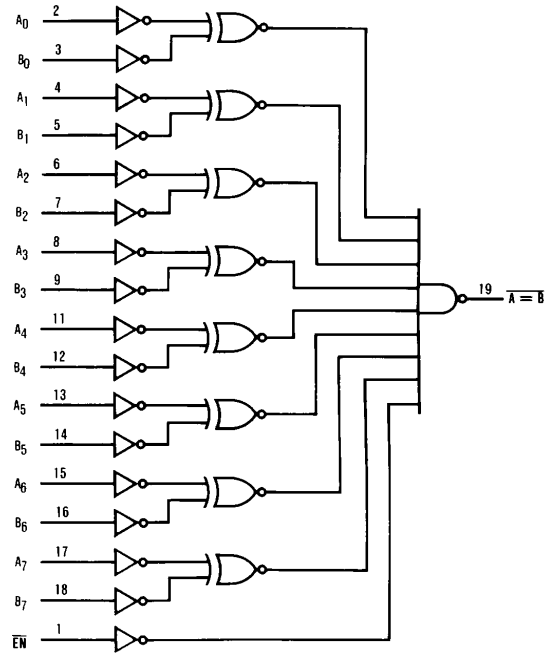

TL/F/6114-4

Physical Dimensions inches (millimeters)

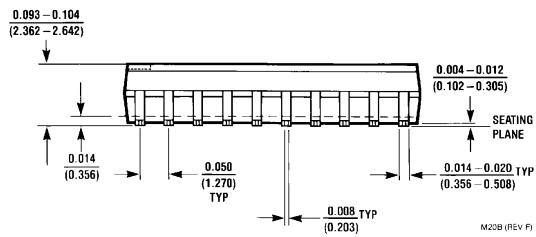
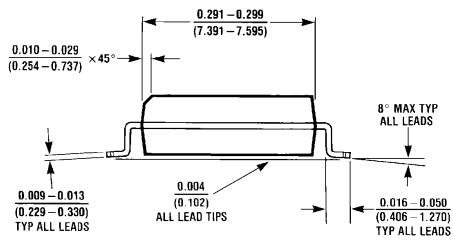
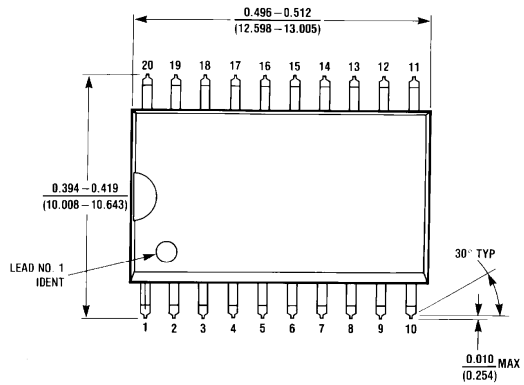

S.O. Package (M)
Order Number DM74ALS520WM or DM74ALS521WM
NS Package Number M20B

Physical Dimensions inches (millimeters) (Continued)

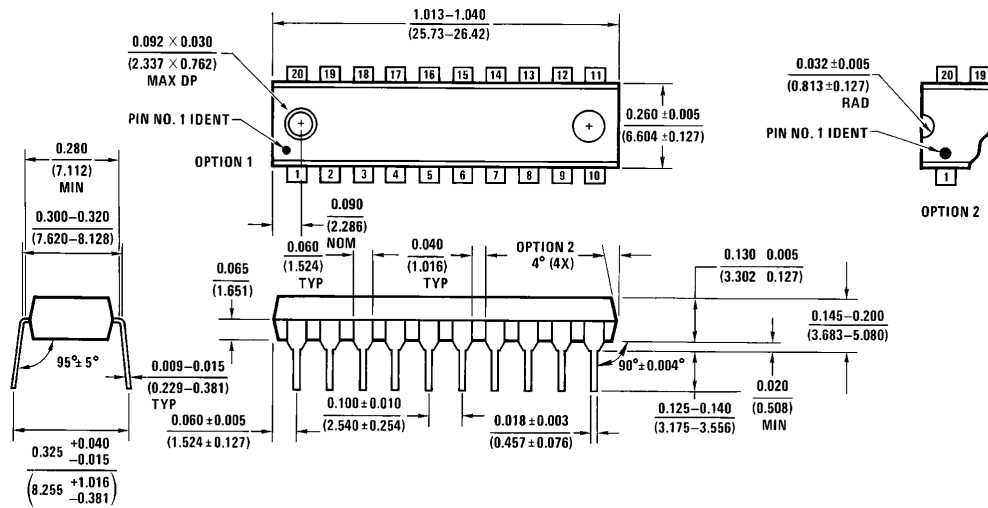

N20A (REV G)

Molded Dual-In-Line Package (N)
Order Number DM74ALS520N or DM74ALS521N
NS Package Number N20A

LIFE SUPPORT POLICY

NATIONAL'S PRODUCTS ARE NOT AUTHORIZED FOR USE AS CRITICAL COMPONENTS IN LIFE SUPPORT DEVICES OR SYSTEMS WITHOUT THE EXPRESS WRITTEN APPROVAL OF THE PRESIDENT OF NATIONAL SEMICONDUCTOR CORPORATION. As used herein:

1. Life support devices or systems are devices or systems which, (a) are intended for surgical implant into the body, or (b) support or sustain life, and whose failure to perform, when properly used in accordance with instructions for use provided in the labeling, can be reasonably expected to result in a significant injury to the user.
2. A critical component is any component of a life support device or system whose failure to perform can be reasonably expected to cause the failure of the life support device or system, or to affect its safety or effectiveness.



National Semiconductor Corporation
 1111 West Bardin Road
 Arlington, TX 76017
 Tel: 1(800) 272-9959
 Fax: 1(800) 737-7018

National Semiconductor Europe
 Fax: (+49) 0-180-530 85 86
 Email: cnjwge@tevm2.nsc.com
 Deutsch Tel: (+49) 0-180-530 85 85
 English Tel: (+49) 0-180-532 78 32
 Français Tel: (+49) 0-180-532 93 58
 Italiano Tel: (+49) 0-180-534 16 80

National Semiconductor Hong Kong Ltd.
 19th Floor, Straight Block,
 Ocean Centre, 5 Canton Rd.
 Tsimshatsui, Kowloon
 Hong Kong
 Tel: (852) 2737-1600
 Fax: (852) 2736-9960

National Semiconductor Japan Ltd.
 Tel: 81-043-299-2309
 Fax: 81-043-299-2408

National does not assume any responsibility for use of any circuitry described, no circuit patent licenses are implied and National reserves the right at any time without notice to change said circuitry and specifications.